

Controller Mounting:

Note: No Drilling is required. First, with the controller's buss bars facing to your right, insert the two 1/4" bolts through the top two holes on the controller. Next, place the smaller of the two metal brackets (called the shim) over the two bolts. Make sure the edge of the controller is aligned with the edge of the shim. Next place the larger metal bracket over the two bolts, on top of the shim. Again, making sure that the edge is aligned with the controller. Next, install the two nuts onto the bolts and hand tighten, making sure to leave some space for installation over the frame. Slide the controller and brackets over the existing mounting area on the cart. Slide the unit to where it is aligned to the driver's side of the mounting area. Notice that the shim will rest on top of the frame work. Tighten the bolts until the clamping action of the brackets firmly clamp the controller to the cart mounting area. Double check to make sure the controller terminals are facing the passenger side and are not touching any metal area.

Activation Wiring: **Reference the Activation Wiring Diagram**

Controller: The seven wire harness with the yellow, white, green, yellow/w/black tracer, brown, pink, and blue wires is the harness you will be working with in this section.

- The yellow wire will connect to pin number one on the controller using the wire end provided
- The white wire will connect to pin number two on the controller using the wire end provided
- The green wire will connect to pin number three on the controller using the wire end provided
- The yellow wire with the black tracer will connect to the brown wire using the provided wire nut
- The blue wire is not used for this system and should be taped
- The pink wire is not used for this system and should be taped
- After all the connections are secure, due to the location of the controller, spray cote the connections with a non conductive sealer to protect from corrosion. Clean up any loose wiring by securing it neatly with the wire ties from the hardware kit. This will prevent the wires from becoming damaged through vibration and movement.

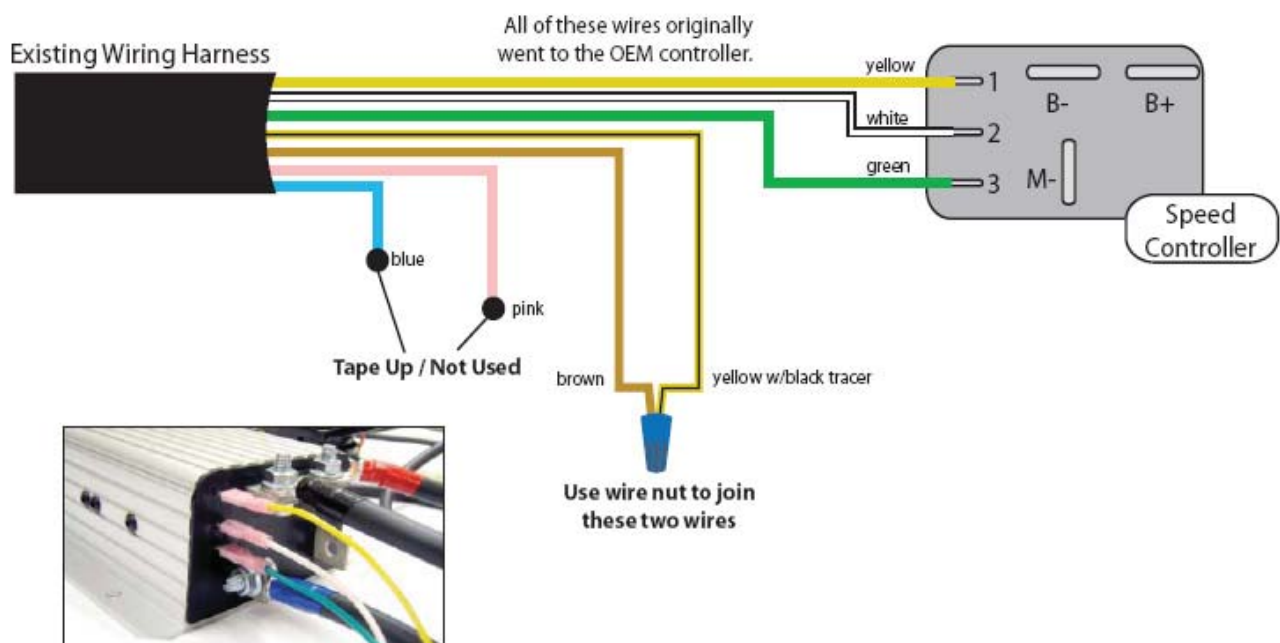

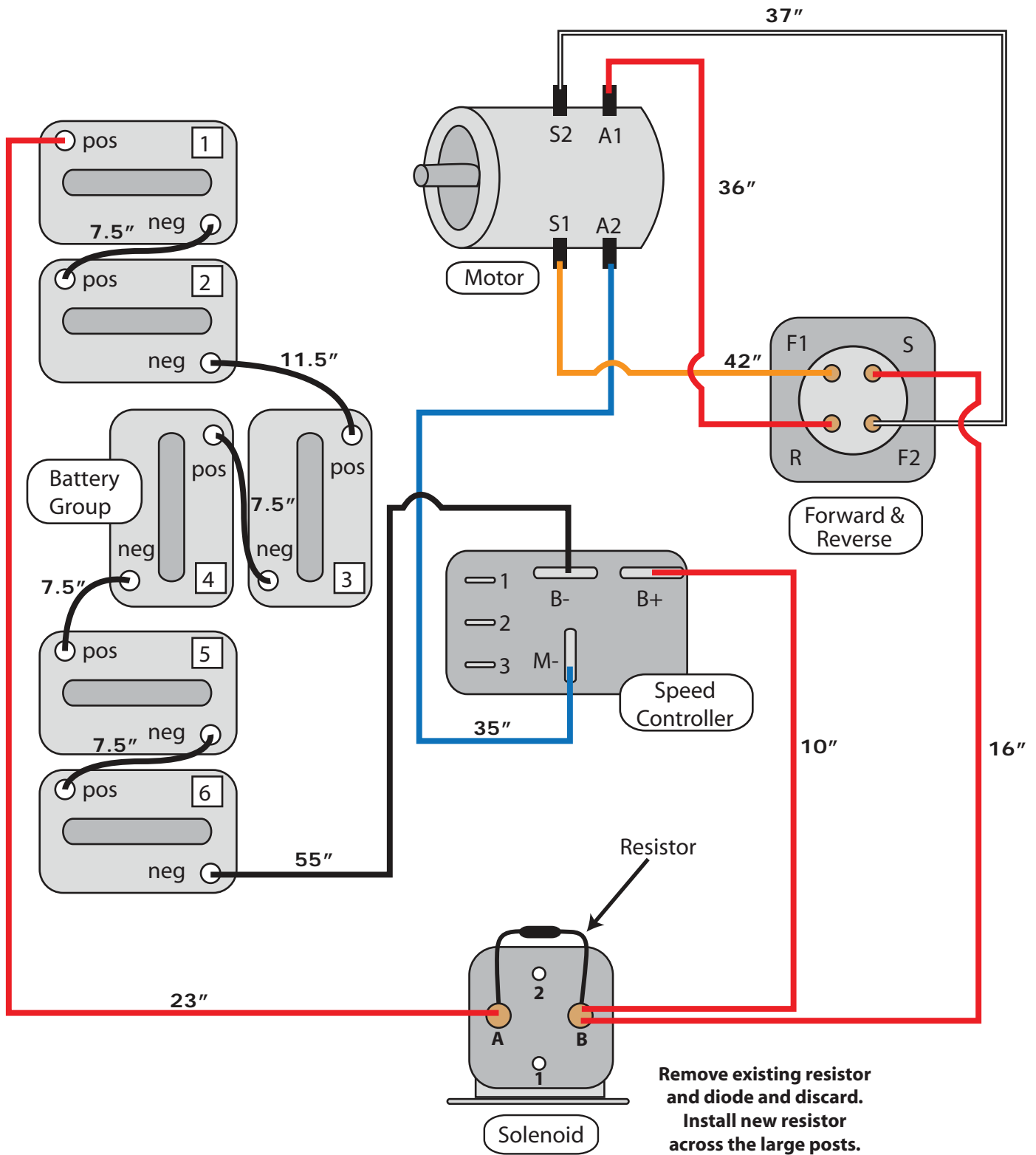

Buggies Unlimited
1-888-444-9994
www.buggiesunlimited.com

© Copyright 1997-2008 Buggies Unlimited. All Rights Reserved.

Controller Bracket Installation

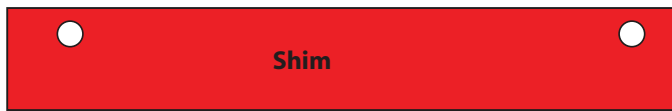
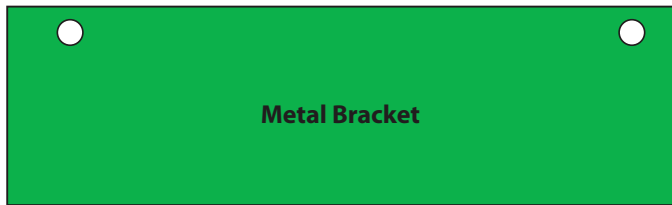
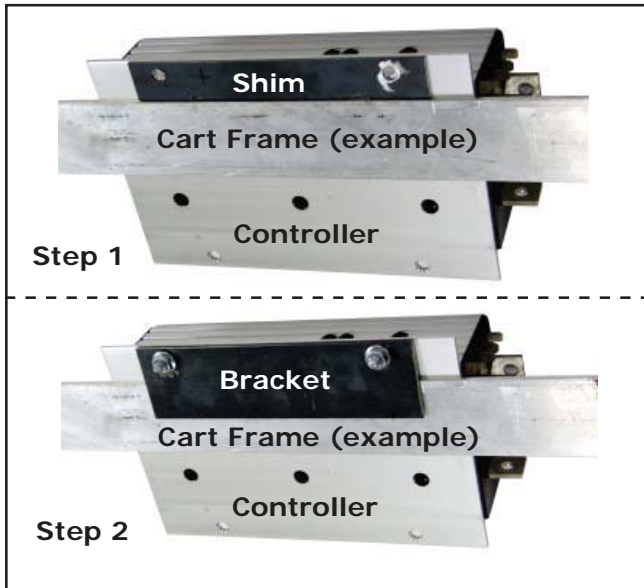

Metal Brackets Included in Kit

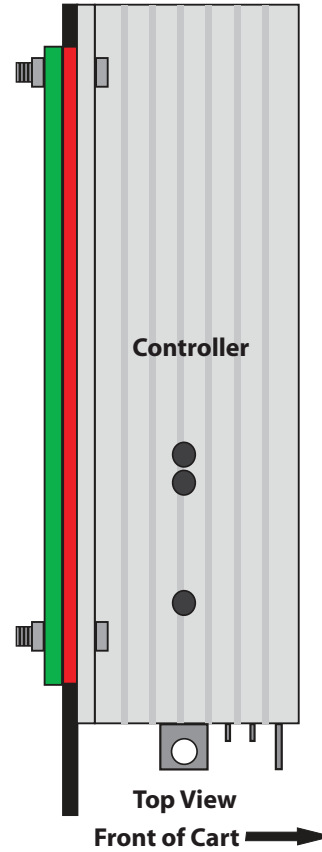

Align the controller with the driver's side edge of the frame.

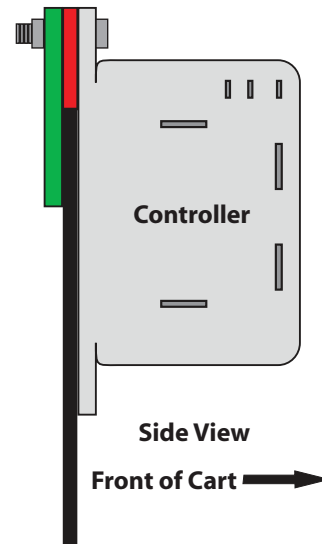
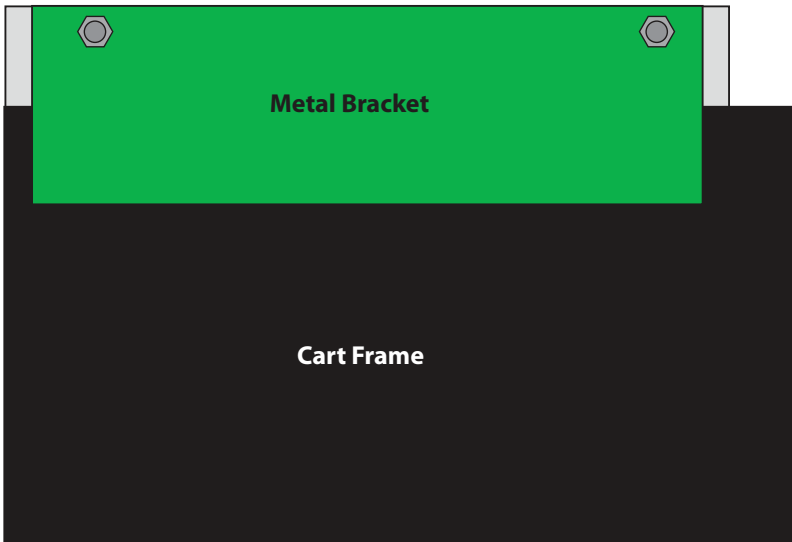

Buggies Unlimited
1-888-444-9994
www.buggiesunlimited.com

© Copyright 1997-2008 Buggies Unlimited. All Rights Reserved.